

MBL500LD

Excellent optical efficiency

The MBL500LD is a long-range marine flashing lantern, with a great optical efficiency and low consumption. Its luminous source consists of high-intensity LED diodes, obtaining a maximum range of 20 nautical miles.

Minimal maintenance

Intended to be placed in on-shore aids-to-navigation locations, requiring minimal maintenance.

High-accuracy lens

Equipped with a high precision lens made of UV resistant acrylic and protected by an impact resistant tempered glass lens cover. Manufactured with high-quality and resistant materials, the MBL500LD provides a long service life under harsh marine conditions.

Designed according to IALA Recommendations.



FEATURES

- *State-of-the-art LED technology.*
- *High-efficiency luminous system.*
Up to 20 nm (T=0.74), 31 nm (T=0.85).
- *Vertical divergence 2° (50% I₀).*
- *Shock-resistant acrylic lens cover.*
- *Average operation lifetime over 15 years.*
- *Photocell adjustable in lux.*
- *IP 67 watertightness degree (immersion resistant).*
- *Linear adjustment of luminous intensity.*
- *Double RS-232 serial port for setting adjustments by PC and remote monitoring system.*
- *Programming, configuration and operating status via PC, IR programmer or Bluetooth.*
- *Short-circuit, reverse-polarity and transient over-voltage protections.*

MBL500LD

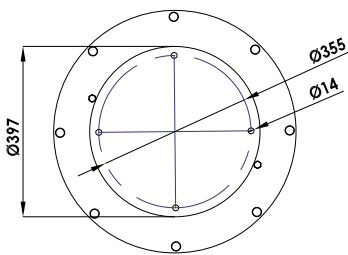
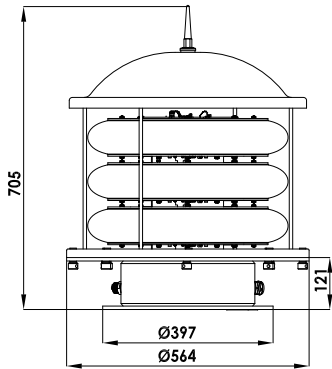

MBL500LD - 3 levels

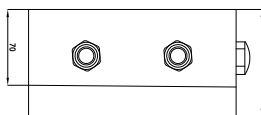
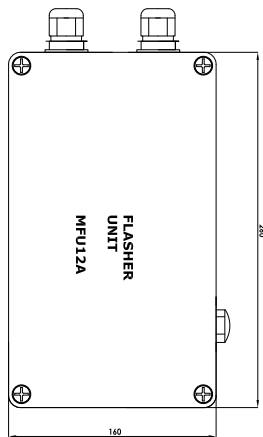

External control unit

Technical Features

Light source:	Ultra-bright LED diodes (2 or 3 levels).
Luminous range:	Up to 20 nm (T=0.74) 31 nm (T=0.85).
Vertical divergence:	Up to 2° (50% I ₀).
LED average life:	More than 100.000 hours.
Power supply:	From 20 to 36 V.
Lantern consumption:	150 W per level.
Flash rhythms:	256 (6 nos. user selectable).
Base:	Marine grade aluminium with polyurethane finishing.
Lens cover:	Acrylic, UV stabilised.
Watertightness degree:	IP 67.
Programming:	PC, Bluetooth or IR programmer.

Options

- PC programming kit.
- RS-485 MODBUS serial port.
- Top flat cover as an option.
- Other specifications available under request.
- MBL500LD-SYNC (GPS synchronisation).
- MBL500LD-TG (GSM remote monitoring).
- MBL500LD-TR (Radio remote monitoring).
- MBL500LD-TS (Satellite remote monitoring).
- MBL500LD-AIS (AIS AtoN).

Peak intensities (Cd)

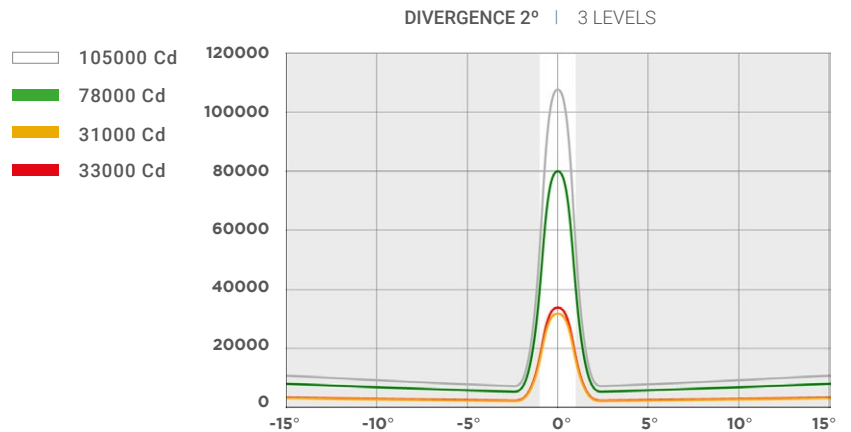

! Specifications subject to change without previous notice.